

HELIOS 85



language



pasquali

HELIOS 85

Low profile tractor with differentiated wheels and short wheel base.

Helios 85 was developed to satisfy customers looking for a solid and performing machine, with basic and essential set-up.

The oversized rear wheels guarantee traction also on difficult terrain, while the front wheels with smaller diameter ensure contained turning radii.

Compact, agile and with low centre of gravity, Helios 85 is the ideal tractor for working in orchards and vineyards, also on slopes, olive groves, greenhouses, canopy plantations or characterised by low foliage.

WIDE RANGE OF OPTIONALS

Rear lift with position and draft control, hydraulically controlled upper link and tie rod link arm, hydraulic circuit with increased flow rate for lift and control valves, front bumper, adjustable steering wheel, Self Cleaning System™, front weights and for wheels, cast iron flanges for 20" and 24" rear wheels.



Levers for control valves operation
all grouped on the right side.

PTO engagement control
positioned on the right mudguard.

Gear levers in forward position
for much easier access on-board.

24" rear wheels
for maximum drive.

Ball joint lifting capacity
of 2700 kg

Kohler engine
75 hp 4-cylinder Turbo Intercooler.

LED working lights (opt.),
compact and streamlined design to work in vegetation-rich environments.

Generous driving platform
for greater operating comfort.

CLEAN POWER

Helios 85 is equipped with a **75 hp 4-cylinder Turbo Intercooler Engine** with particulate filter, that BCS Group worked on in collaboration with Kohler for an advanced regeneration strategy guaranteeing maximum performance and reducing machine downtime to a minimum.

The rpm is electronically controlled quickly by an hand lever and a button for memorize and recall the set speed.

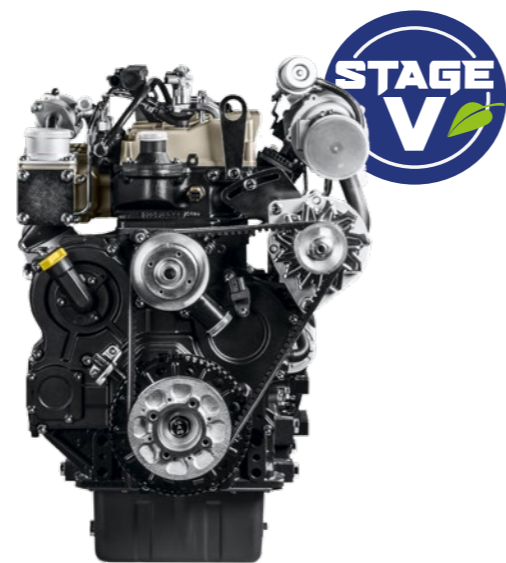

ERGONOMICS AND COMFORT

The driving position was designed to combine ergonomics and comfort with **close attention to the layout of the controls** according to the logic applied to open field tractors.

The new work station features **all operating levers for control valves and lift positioned on the right side**, also in the version with position and draft control, and the right mudguard now has an **electro-hydraulic control for PTO engagement**.

Accordingly all of the controls for hydraulics can be easily used by the operator with his/her right hand, while the left hand stays firmly on the steering wheel.

Also, from the seat the operator has a complete and unobstructed view of the rear implement as well as the machine and wheel track.

The generous platform and the greater seat travel increase the space for the lower limbs and allow optimal use of the pedals.

Access to the driver's seat has been made much easier by the forward position of the gear and reverser levers.

The cushioned and adjustable seat, based on the operator's weight, and the **height-adjustable steering wheel** (opt.) help alleviate some fatigue even after many hours of work.



PTO engagement control

HELIOS 85 RS

Data Sheet

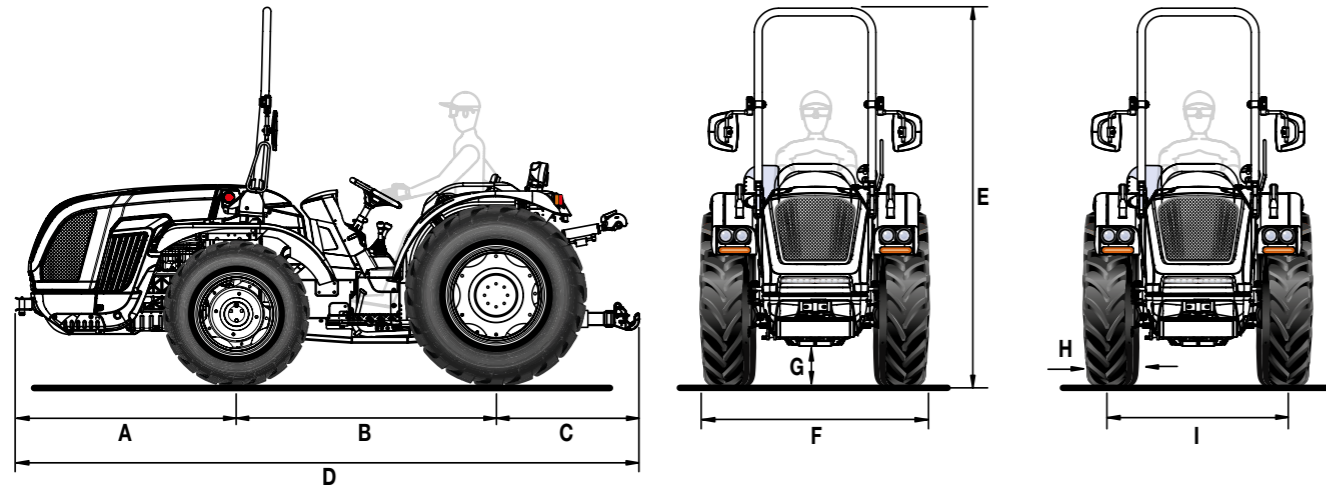

A	B	C	D	E min/max	G min/max
1348	1607	968	3923	2216 / 2291	157 / 232

* Dimensions in mm

	260/70 R16	300/70 R20	260/70 R16	340/65 R20	250/80-16	320/85 R20	280/70 R18	360/70 R20	280/70 R18	420/65 R20
	anteriore	posteriore	anteriore	posteriore	anteriore	posteriore	anteriore	posteriore	anteriore	posteriore
H	258	295	258	343	240	319	265	357	265	418
I	1122 / 1522	1054 / 1490	1122 / 1522	1054 / 1490	1122 / 1522	1054 / 1490	1098 / 1538	1170 / 1490	1098 / 1538	1170 / 1490
F	1380 / 1780	1349 / 1785	1380 / 1780	1397 / 1833	1362 / 1762	1373 / 1809	1363 / 1803	1527 / 1847	1363 / 1803	1588 / 1908

	250/80-18	280/85 R24 (11.2 R24)	320/65 R18	320/70 R24	320/65 R18	380/70 R20	280/70 R18	380/70 R20	280/70 R18	320/70 R24
	anteriore	posteriore	anteriore	posteriore	anteriore	posteriore	anteriore	posteriore	anteriore	posteriore
H	240	292	319	316	319	380	265	380	265	316
I	1098 / 1538	1034 / 1518	1166 / 1470	1132 / 1518	1166 / 1470	1170 / 1490	1098 / 1538	1170 / 1490	1098 / 1538	1034 / 1518
F	1338 / 1778	1326 / 1810	1485 / 1789	1451 / 1837	1485 / 1789	1550 / 1870	1363 / 1803	1550 / 1870	1363 / 1803	1353 / 1837

* Dimensions in mm - min / max
H = Tyre width - I = Wheel track - F = Tractor width

TECHNICAL FEATURES	HELIOS 85 RS
ENGINE	Kohler KDI 2504 TCR
No. of cylinders	4 in-line / 16 valves
Displacement (cc)	2482
Intake	Turbo / Intercooler
Fuel system	"Common rail" direct injection - 2000 bar
Emissions compliance	Stage V
Balancing	Counter-balance shafts
Power (kW/hp)	55.4 / 75.3
Rated speed (rpm)	2300
Max torque (Nm/rpm)	300 / 1500
Engine speed management	Electronically regulated via hand lever and button with function for memorize and recall the set speed
Cooling	Liquid
Tank capacity (l)	78
CHASSIS	Swinging integral chassis (±15°) OS-FRAME with steering wheels
DRIVE	Four-wheel drive. Front-wheel drive disengagement with electro-hydraulic control
TRANSMISSION	32-speed synchronised gearbox: 16 FWD and 16 REV with synchronised reverser
Min/max travel speed (km/h)	0.7 / 40
Transmission clutch	Multidisc in oil bath with hydraulic control
DIFFERENTIAL	Front and rear. Differential lock: front and rear simultaneously or rear only with electro-hydraulic control
AXLES	Front with planetary reduction units and rear with bull-gear units
REAR PTO	Independent from the gearbox and synchronised with the forwarding speed. Negative safety hydraulic brake to stop the PTO
PTO clutch	Multidisc in oil bath with electro-hydraulic control
PTO rotation speed (rpm)	Standard: 540/540E - Optional: 540/1000
HYDRAULIC SYSTEM	Dual circuit with independent pumps and heat exchanger
Flow rate to the hydroguide and the electro-hydraulic controls (l/min)	33.5
Flow rate to the lift and the control valves (l/min)	29.5 (optional oversized pump with 51 l/min flow rate)
Maximum hydraulic pressure (bar)	180
REAR CONTROL VALVES	Mechanically controlled
Standard	1 double-acting with float + free flow oil return (total 3 hydraulic outlets)
Optional and in addition to the standard ones	2 double-acting (total 7 hydraulic outlets) or 1 double-acting and 1 double-acting with lockable position (total 7 hydraulic outlets)
REAR LIFT	By two external rams. Standard: raising/lowering - Optional: position and draft control
3-point implement hitch	Standard: Normal couplings cat. 1 and 2. Optional: fixed arms with quick-couplings cat. 1 and 2 or L-shaped arms with quick-couplings cat. 1 and 2
Third point tie rod	Standard: with manual adjustment - Optional: hydraulically controlled upper link and tie rod link arm
Ball joint lifting capacity (kg)	2700
DRIVING POSITION	Monodirectional with footstep driving position
Steering wheel	Standard: fixed - Optional: height adjustable
Seat	With safety belt and man-on-board sensor. Standard: comfort seat with adjustable spring tension according to the operator's weight - Optional: 'Kab' lowered seat
SERVICE BRAKES	Multidisc in oil bath with mechanical control, acting on the rear wheels with automatic engagement of the 4-wheel drive. Independent manoeuvring brakes acting on the rear wheels
Parking brake	Acting on service brakes
STEERING	Hydrostatic steering acting on the front wheels
SAFETY	Front homologated roll-bar with gas springs for easy lowering and lifting
DASHBOARD	With TFT colour display showing: hours of operation, engine rpm, forwarding speed, PTO rpm, particulate filter clogging level, instantaneous fuel consumption, battery voltage and current time. Analogue instrumentation complete with engine rpm, engine coolant temperature and fuel level indicator. Warning lights and acoustic alarm
ELECTRIC SYSTEM	Battery 80 Ah / 12 V - Alternator 95 A
Standard equipment	Vehicle Control Unit, street light and indicator system, single-pole dashboard socket, rear 7-pin and 3-pin sockets
TYRES	260/70R16*300/70R20 - 260/70R16*340/65R20 - 250/80-16*320/85R20 - 280/70-18*360/70R20 - 280/70R18*420/65R20 - 250/80-18*280/85R24 - 320/65R18*320/70R24 - 320/65R18*380/70R20 - 280/70R18*380/70R20 - 280/70-18*320/70R24
TOW HOOKS (standard)	Front - Rear CUNA cat. C adjustable in height
Optional	Rear tow hook: EC approved or EC with Slider frame or CUNA with Slider frame or EC tow bar with Slider frame
RUNNING ORDER WEIGHT with roll-bar (kg)	2260
ADDITIONAL OPTIONS	Front bumper, beacon lamp, front LED working lights, rear adjustable working light, Self Cleaning System™, front weights kg 150, wheel weights kg 50 each, cast iron flange kg 50 each for 20" rear wheels, cast iron flange kg 70 each for 24" rear wheels

THE SERVICES



SPARE PARTS

A complete range of original spare parts, guaranteed directly by the manufacturer.



ASSISTANCE

A team of specialists, well prepared and available to assure an efficient and resolving service.



LUBRICANTS

We recommend to use the original PowerLube lubricants.



FINANCIAL SERVICES

Financial solutions to meet the credit requirements.



MADE IN ITALY